

SHOW PRODUCT

Switchgear accessories series

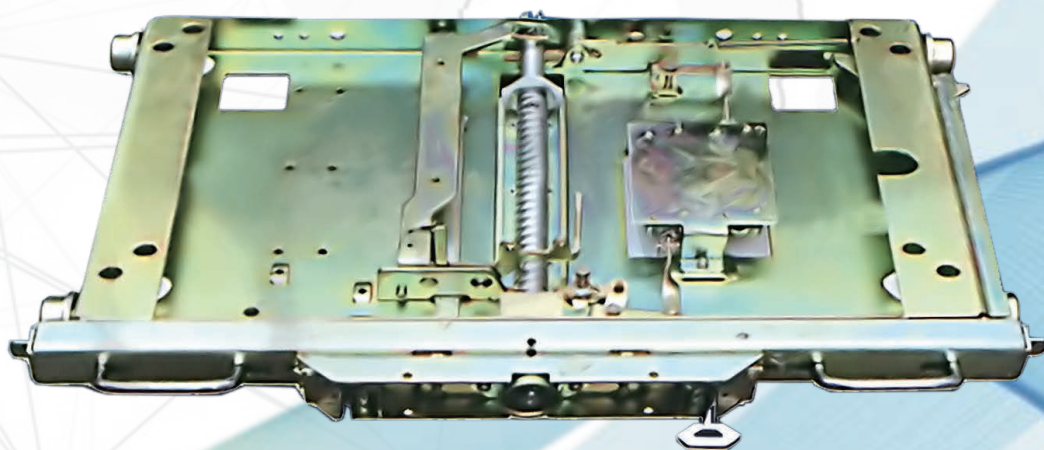

CHASIS TRUCK SERIES

Model and meaning :

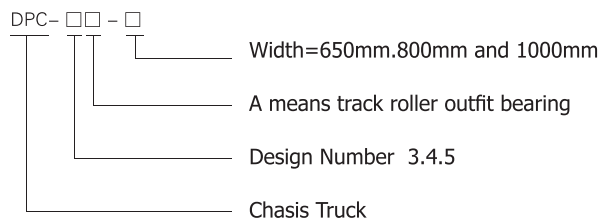

Usage and function :

Chasis truck mainly used for switch equipment to install circuit breaker, transformer and other components, push and exit it ,play a supplementary role in connecting the components with the busbar.

When chasis truck works with the internal mechanism of circuit breaker and other switchgear interlocking mechanism ,can meet the interlock requirement of GB3906-five prevention.

Lock plate for Chasis Truck



Lock plate 8XS.141.012

Lock plate 8XS.141.012.1

Lock plate 8XS.141.012.2

Lock plate 8XS.141.050
(For VSm)

Lock plate 8XS.141.012S
(For VS1+)

Note:DPC chasis truck has five lock plates for selection,usually with 8XS.141.012.2,if you need to match the other four lock plates,please declare in order.

MOTORIZED CHASSIS TRUCK

DD-2B+Control module for motorized chassis truck

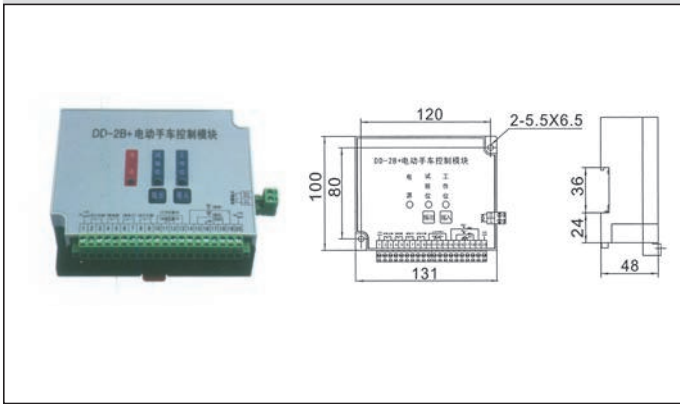

DD-3A Control module for motorized chassis truck

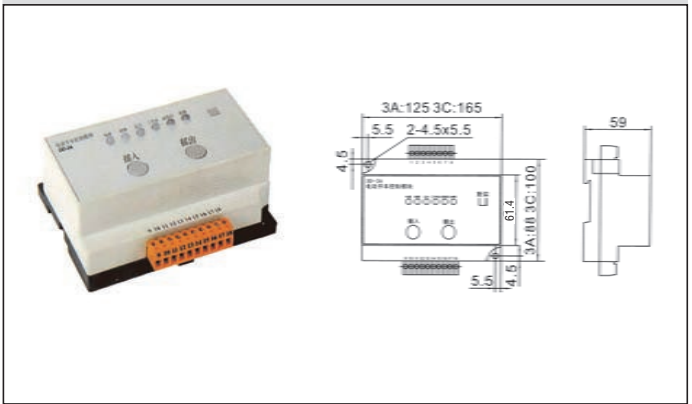

DD-3B Internal type control module motorized chassis truck

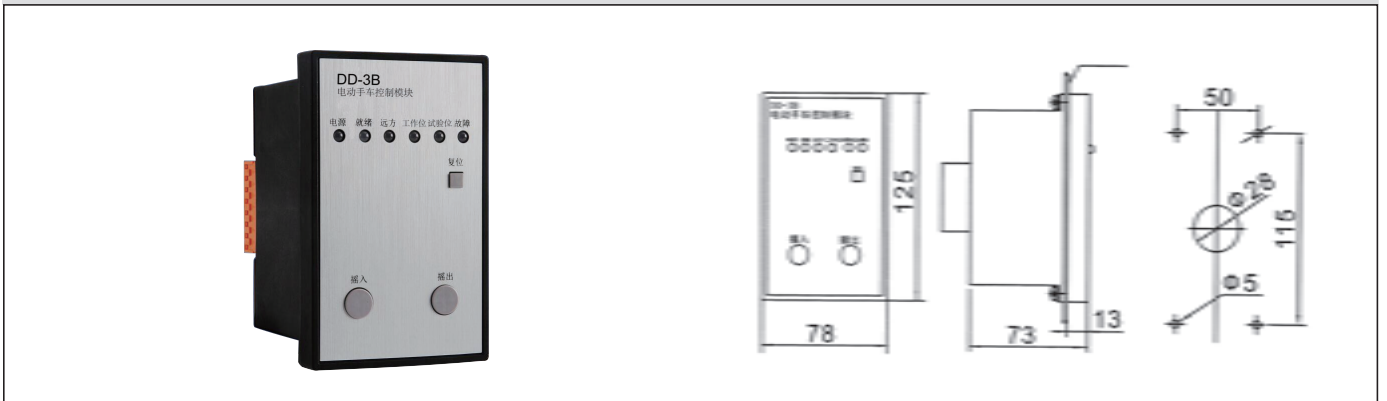

DPC-max-550 chasis truck and DPC-max-550/DD3motorized chassis truck



DPC-4-650/VD4 Chassis truck

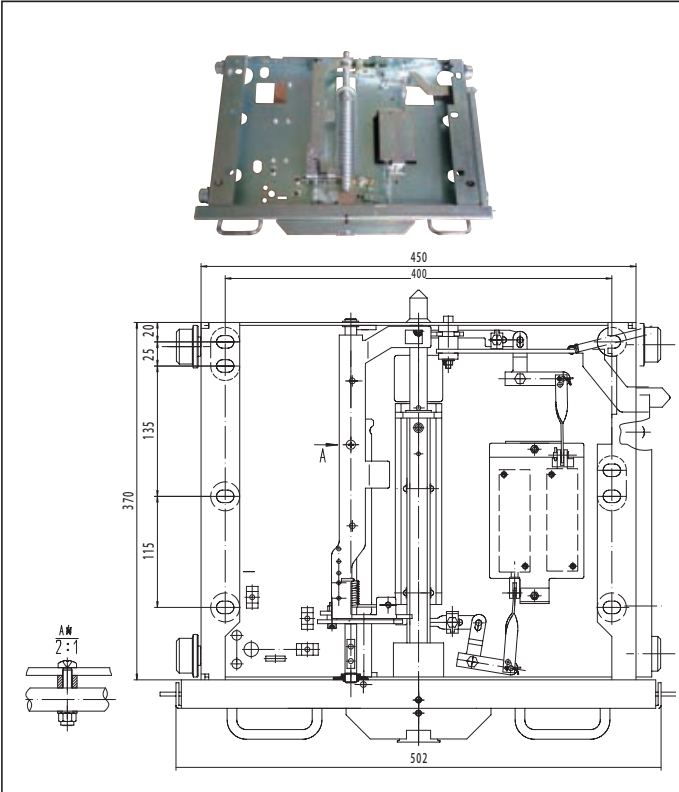

DPC-4-750/VD4 Chassis truck

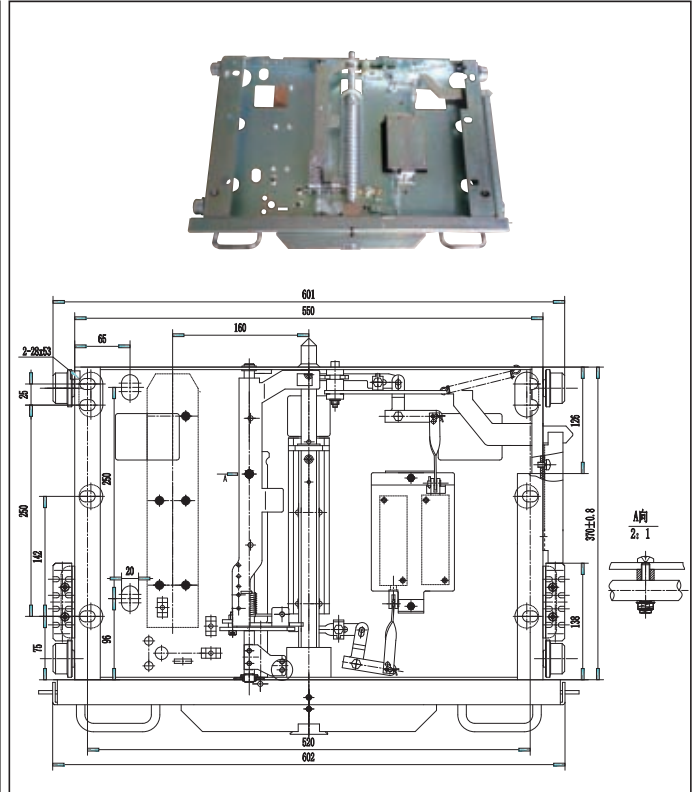

DPC-4-800/VD4 Chassis truck

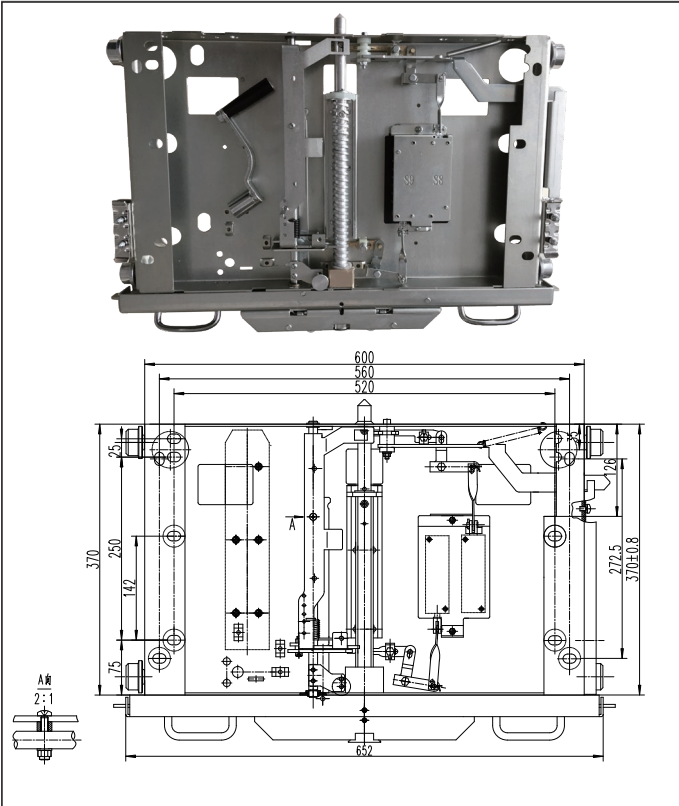

DPC-4-1000/VD4 Chassis truck

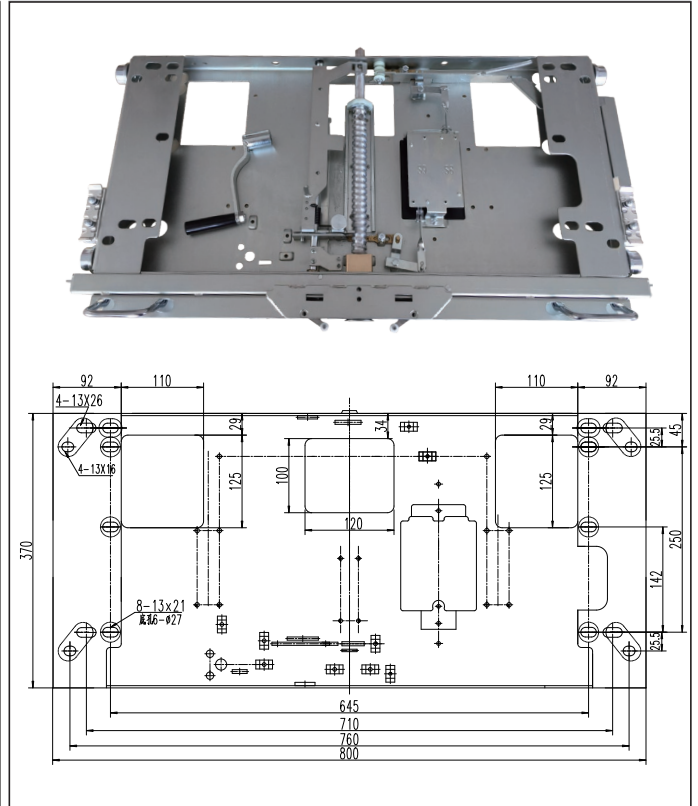

DPC-4-550- DD3 Chassis truck (motorized type)

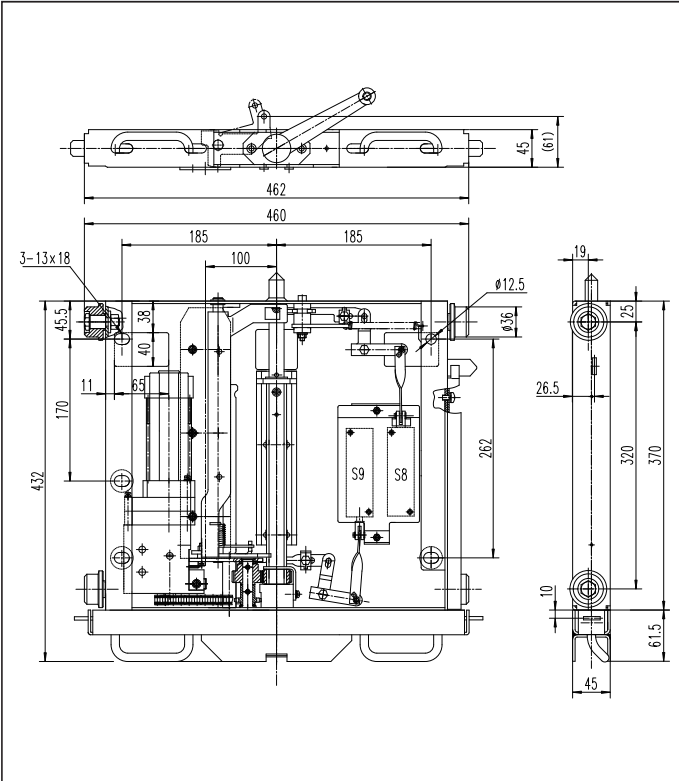

DPC-4-650- DD3 Chassis truck (motorized type)

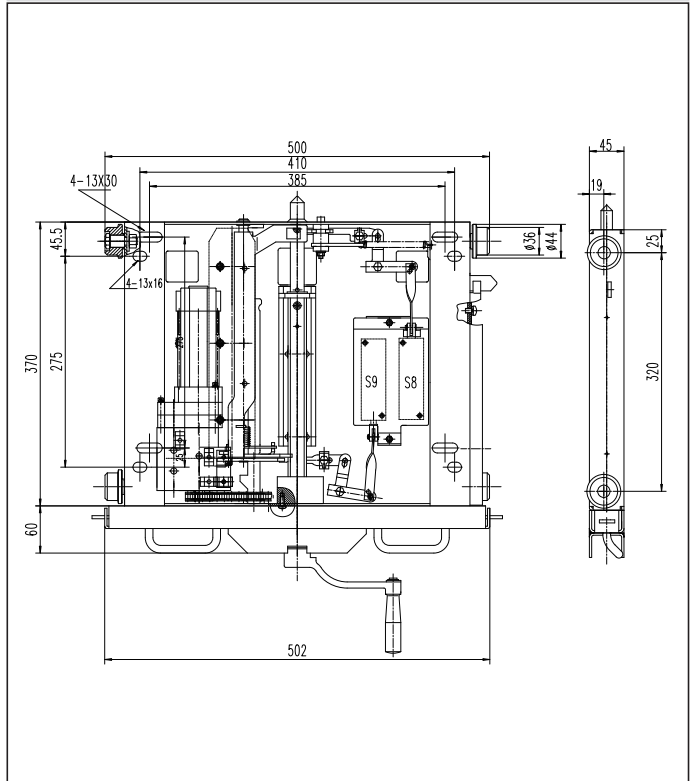

DPC-4-800- DD3 Chassis truck (motorized type)

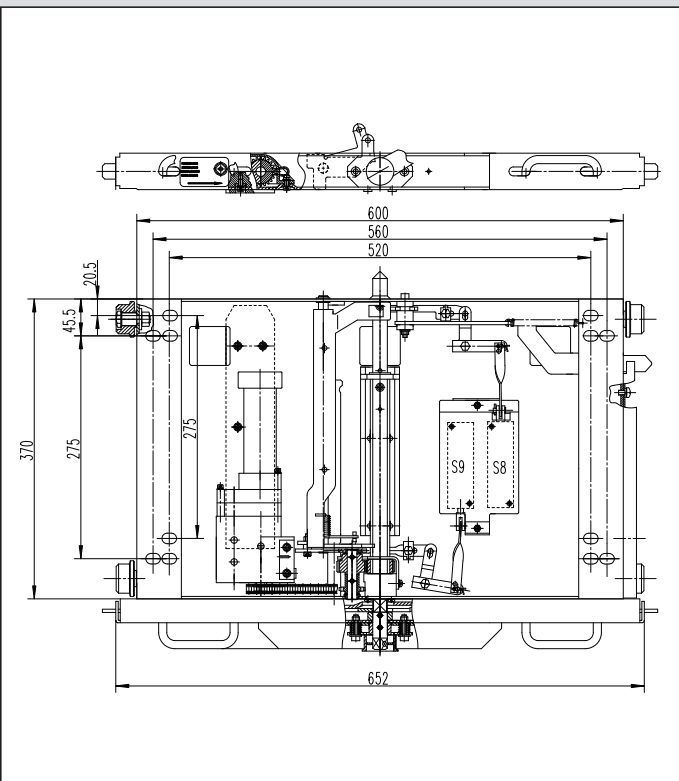

DPC-4-1000- DD3 Chassis truck (motorized type)

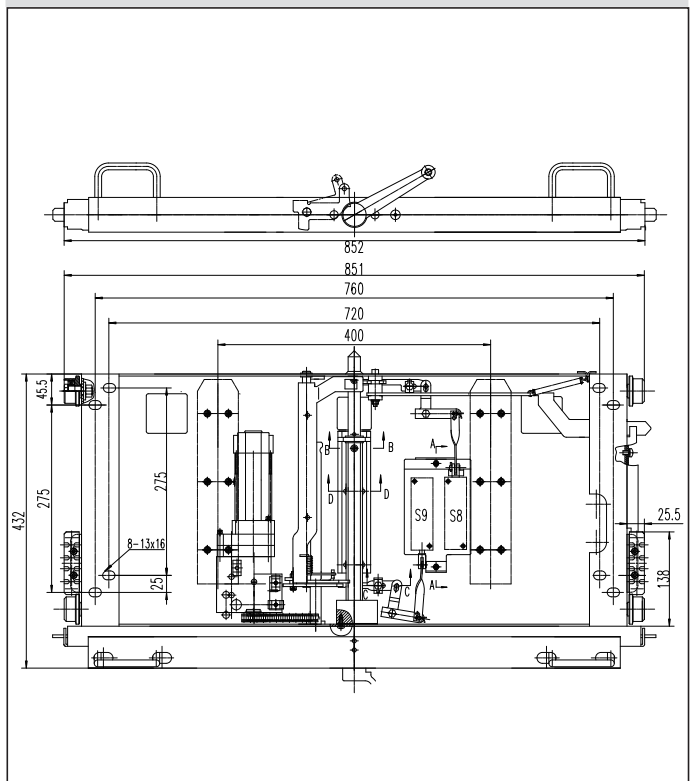

DPC-4-450 Chassis Truck

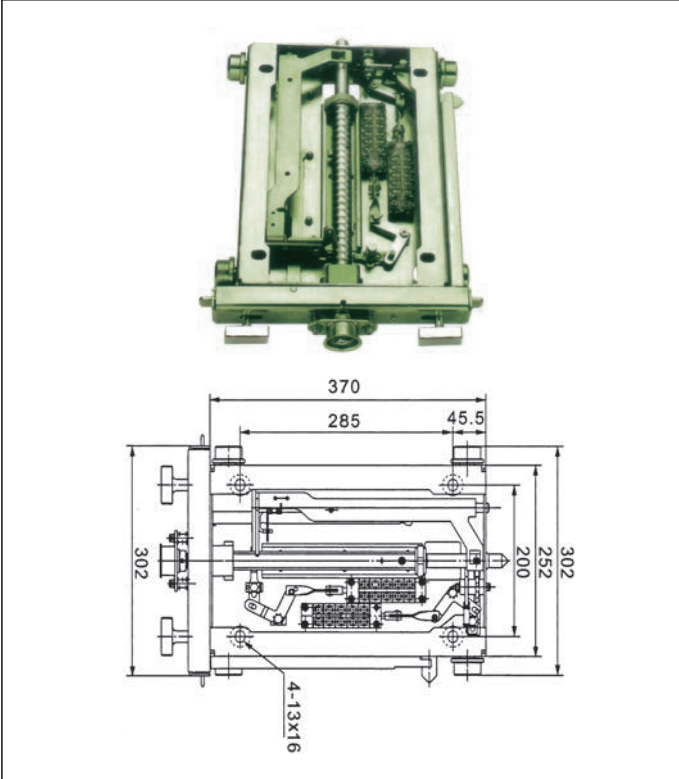

DPC-4-550 Chassis Truck

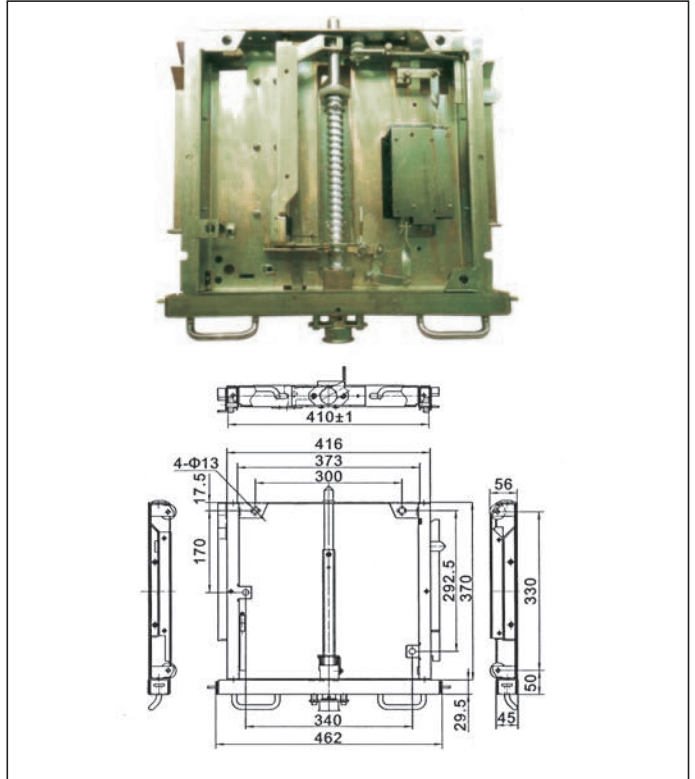

DPC-3-800 Chassis Truck

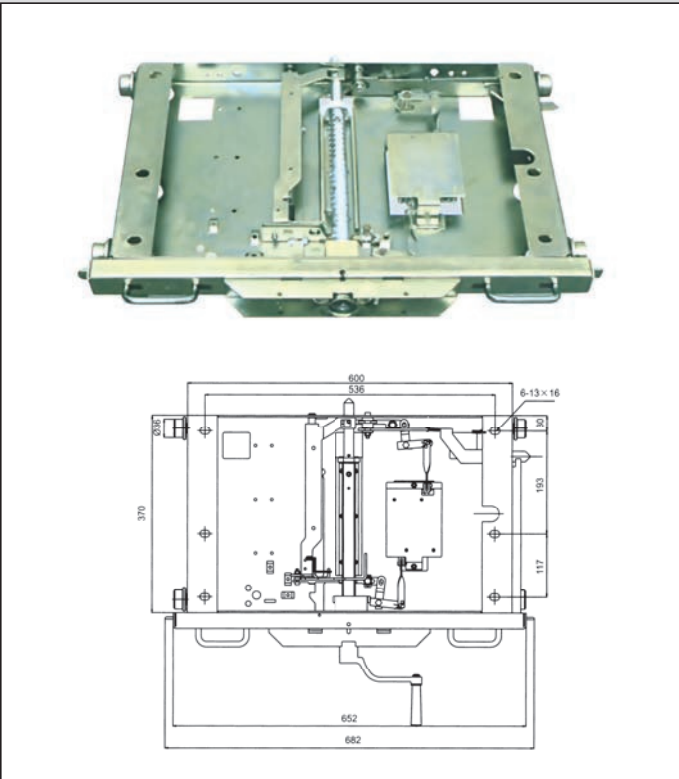

DPC-4-750 Chassis Truck

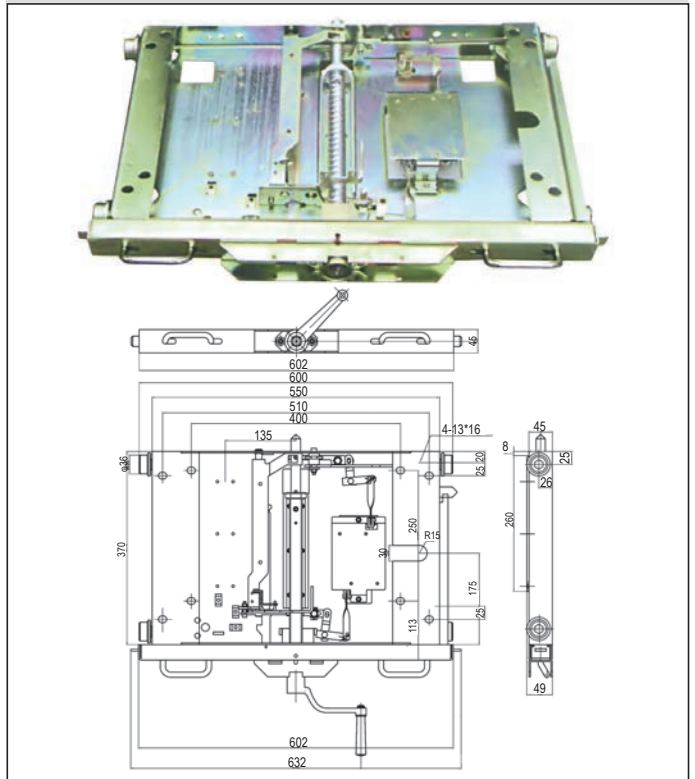

DPC-4-□Chassis Truck

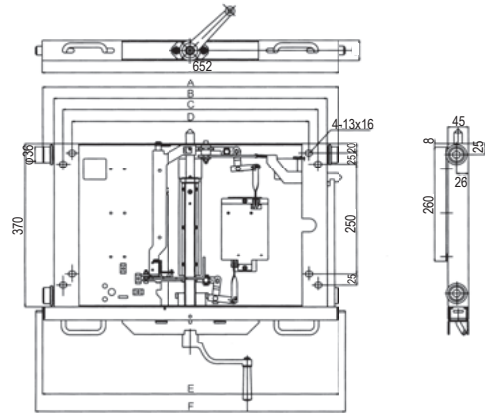
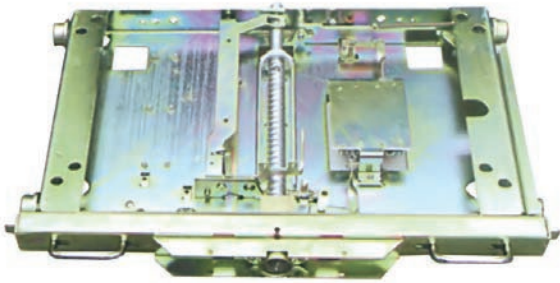

Model	A	B	C	D	E	F
DPC-4-650	500	450	410	385	502	535
DPC-4A-650				$\phi 13 \times 30$		
DPC-4-800	650	600	560	520	652	685
DPC-4A-800						

DPC-4-900 Chassis Truck

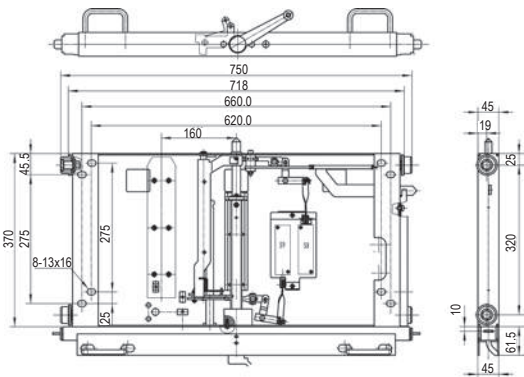
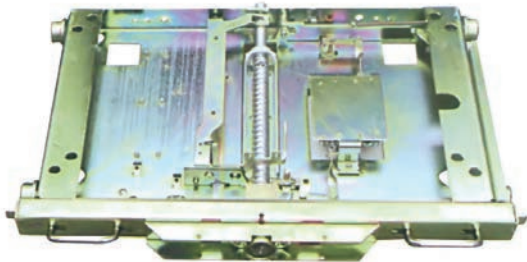

DPC-4-1000 Chassis Truck(For VBI)

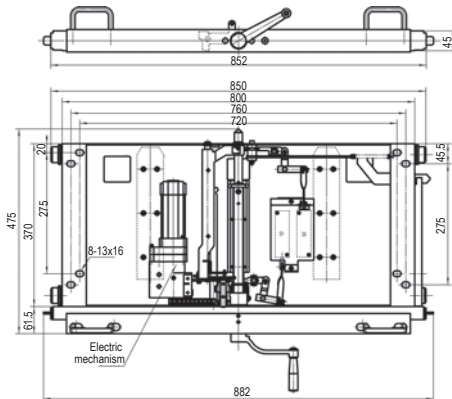
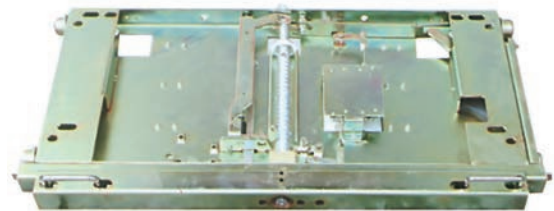

DPC-5-□Chassis Truck(For VBI)

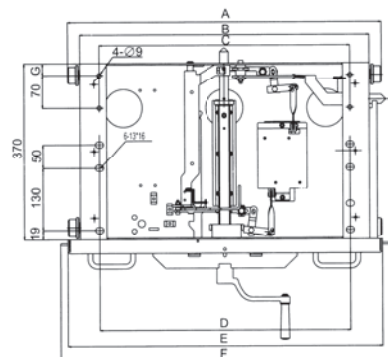
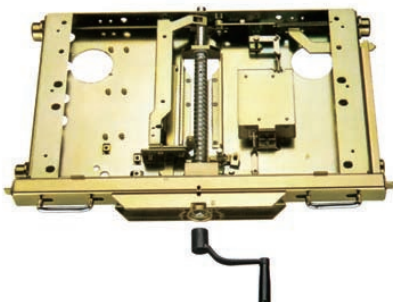

Model	A	B	C	D	E	F	G
DPC-5-800	650	600	520	520	652	685	25
DPC-5A-800							
DPC-5-1000	850	800	720	700	852	885	45
DPC-5A-1000							

Earthing bar installation diagram

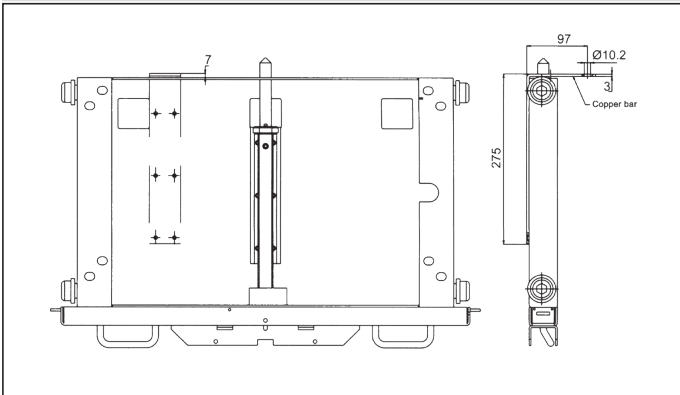

Earthing clip installation diagram

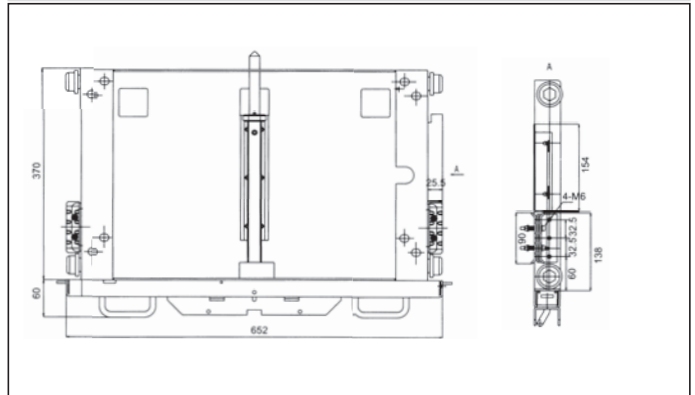

DPC-□-□Chassis Truck

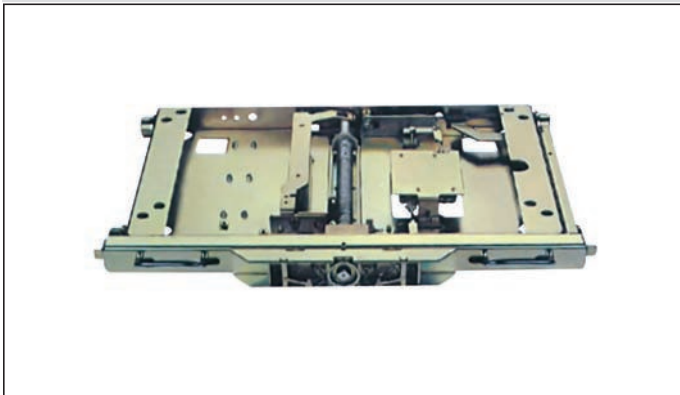

DPC Chassis Truck door interlock functions:

a.DPC-□-□/G Chasis Truck

This chassis truck can be operated only when the cabinet door is closed,no need to change the cabinet door.

b.DPC-□-□/ S Chasis Truck

This chasis truck increase the lock function based on item a,it means when the handcart leave the test position ,cabinet door is locked,can't be opened,only back to the test position,cabinet door can be opened,it needs to change the door.

24kV Deepen type chassis truck 800-1000

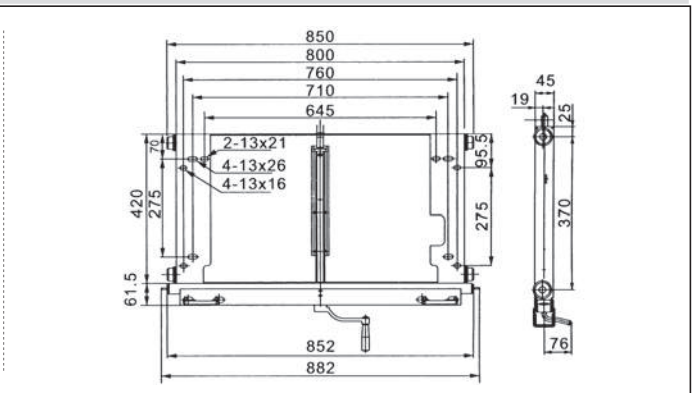
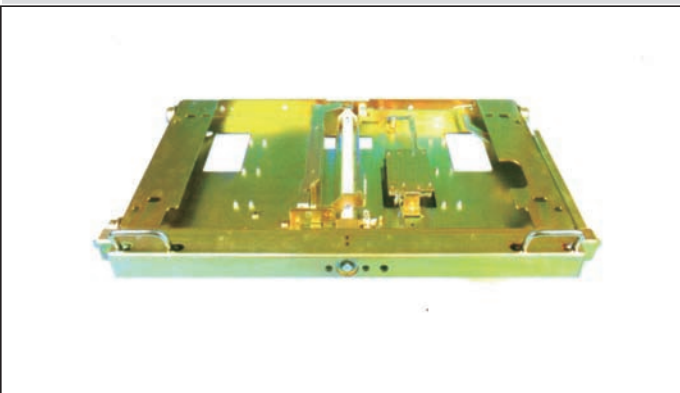

DPC-40.5-1200 chassis truck

